

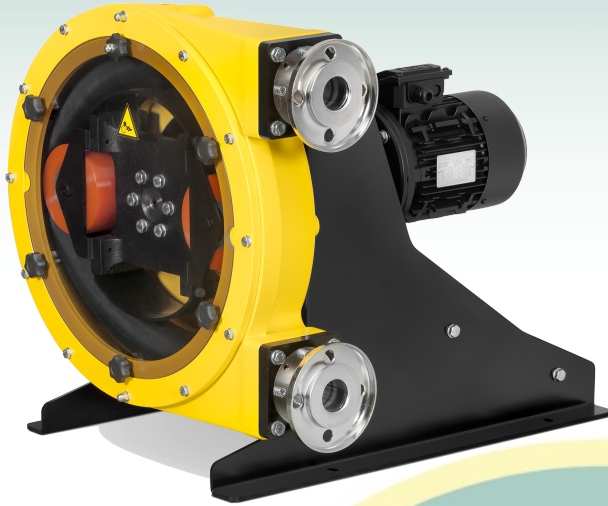

Industrial Peristaltic Pumps

FMP-50/B Data sheet



Capacity: 1,47 l/rev.
Connections: DN-40
Max. Pressure: 8 bar
Rotor system: Enlarged Rollers
Available hoses: NR
NBR
EPDM
HYPALON
NR-A
NBR-A
Available tubes: TPV

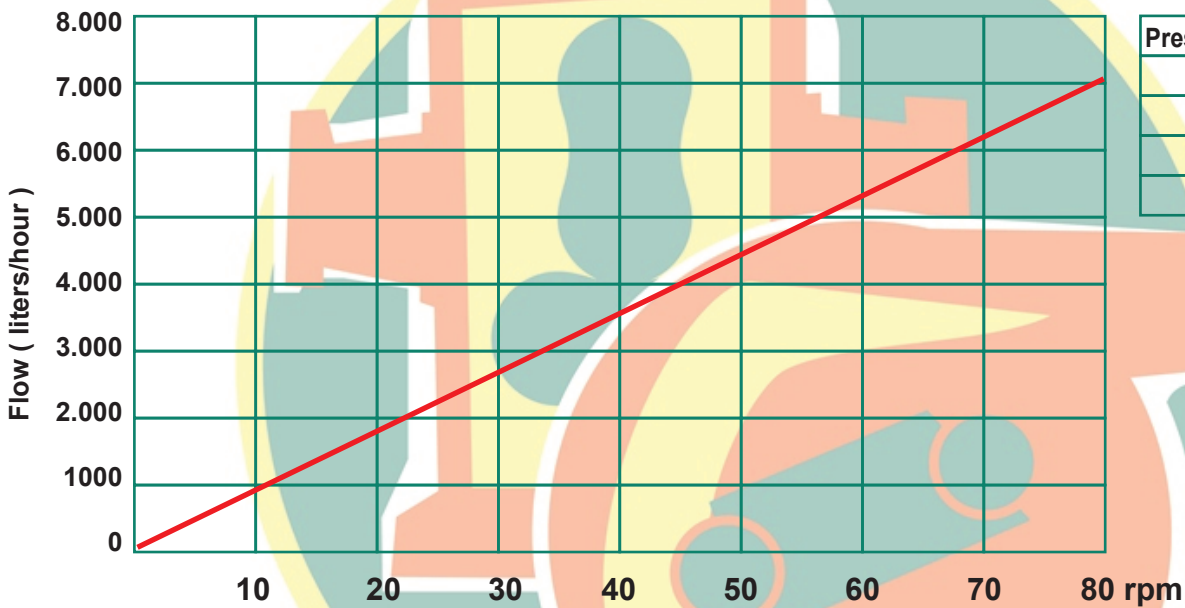

Pressure (bar)	Torque (Nm)
1	130
4	210
6	330
8	500

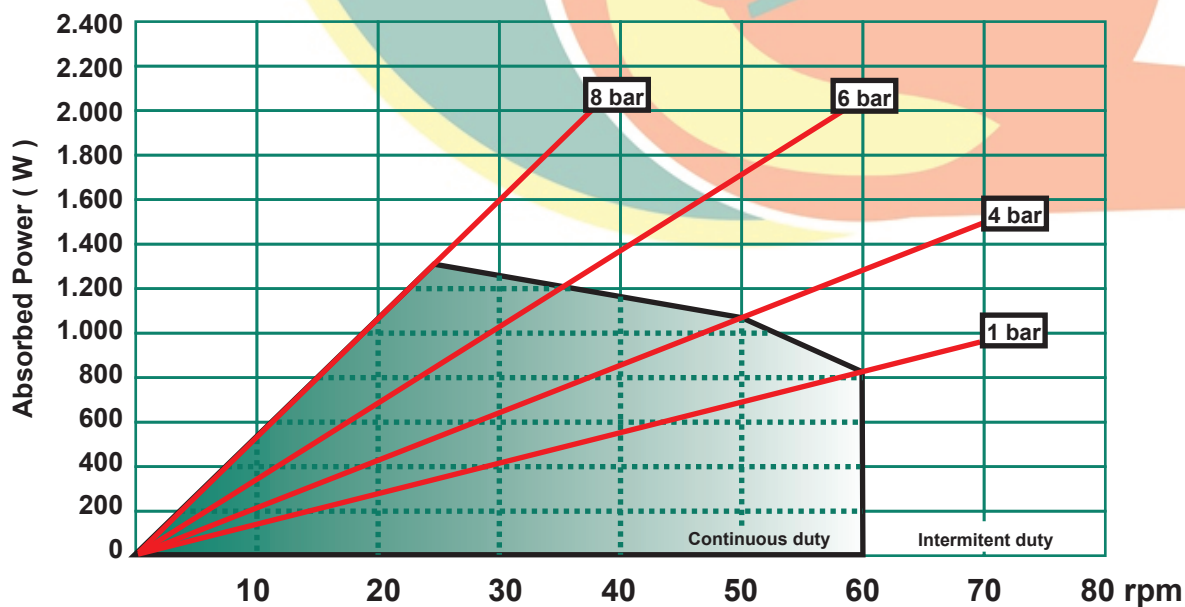

Description	Material	Surface treatment
Pump housing	Cast Iron EN-GJL-250	Polyester powder coated Halar coated (Optional)
Front cover	Steel F-111 / Polycarbonate	Polyester powder coated Halar coated (Optional)
Rotor	Nodular Cast Iron EN-GJL-400	Cataphoresis
Rollers	Steel F-114 + Polyurethane	--
Base plate	Steel F-111 Stainless Steel AISI-304 (Optional)	Polyester powder coated --
Connections	Stainless Steel AISI-304 Polypropylene (Optional) PVDF (Optional)	--

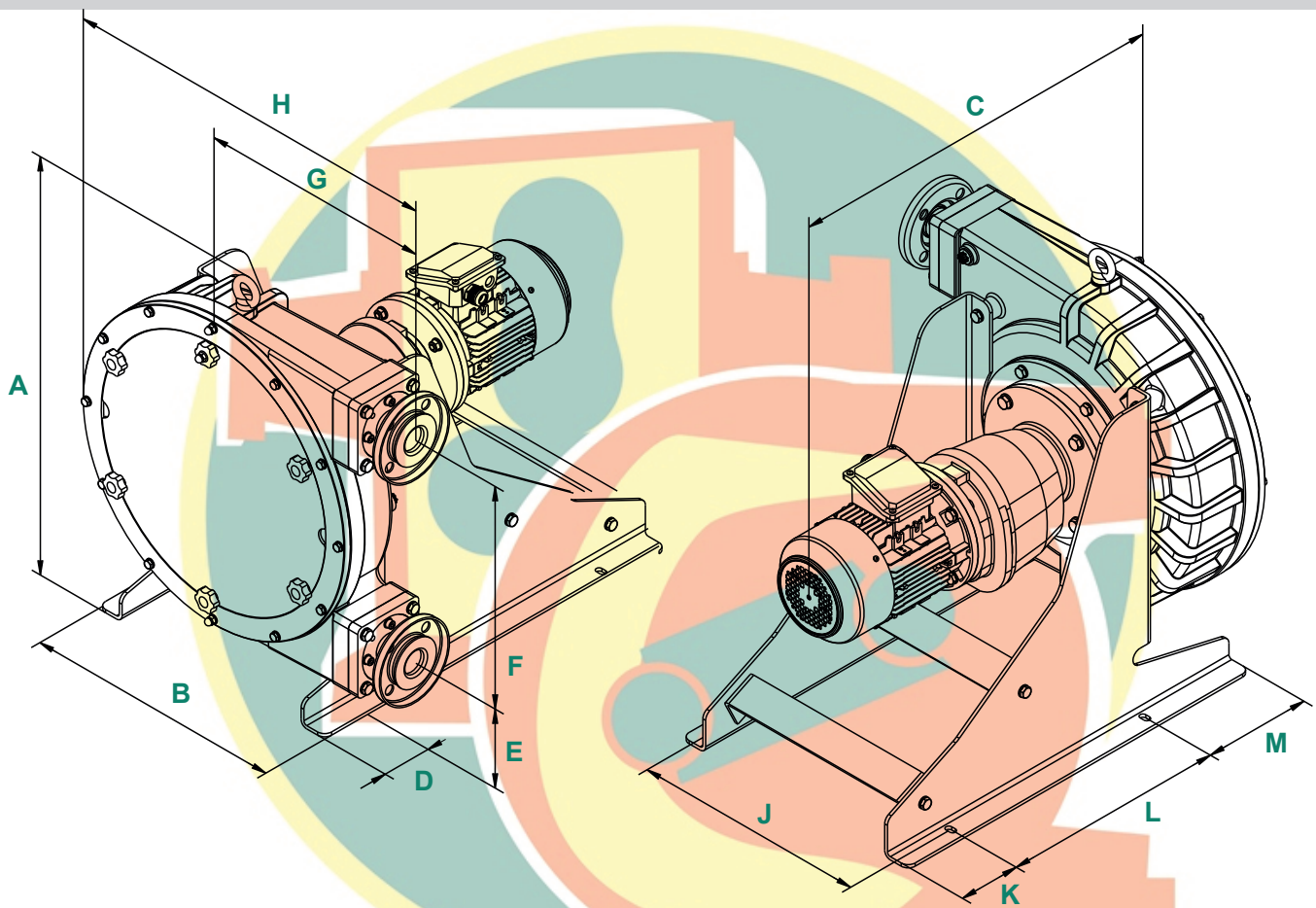

A	B	C	D	E	F	G	H	J	K	L	M	Connections
700	483	*	75	163	412	362	642	435	115	415	200	DIN DIN40

* To confirm according type and power driver.

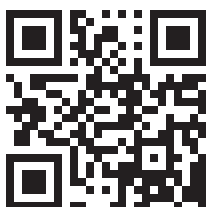

Bombas Boyser, S.L.

c/ Miquel Martí i Pol, s/n - Pol. Ind. Pla de la Costa
08182 Sant Feliu de Codines - Barcelona - Spain

Tel. +34 93 844 77 78 info@boyser.com

www.boyser.com

